



PREPARE FOR SUCCESS IN MTH108

Welcome 'Canes!

If you are currently enrolled in MTH108 for the upcoming semester, we encourage you to spend some time on this packet before the start of the term. We have carefully selected topics that are essential for success in this course.

It is important that you work through this packet on your own, so that you get a clear gauge of your preparation. For each main topic, you will find examples worked out with explanations. After the examples, we have selected problems for you to try on your own. The answers to these problems are found at the end, so you can check your work.

If you feel you need to review certain topics in more depth, we recommend these websites – just search the related topics on the site:

<https://www.khanacademy.org/math/algebra-home>

[YouTube - Patrick JMT](#)

Here's to a great start of the semester and much SUCCESS!!

MTH108 Prerequisite Review

TOPICS

[Arithmetic, Order of Operations, Radicals](#)

[Factoring Polynomials](#)

[Simplifying Expressions](#)

[Your Turn](#)

[Solving Equations](#)

[Quadratic](#)

[Rational](#)

[Radical](#)

[Factoring](#)

[Absolute value](#)

[Quadratic in form](#)

[Your Turn](#)

[Systems of Linear Equations](#)

[Your Turn](#)

[Systems of Non-Linear Equations](#)

[Your Turn](#)

[Geometry](#)

[Functions](#)

[Transformations of basic graphs](#)

[Domain](#)

[Composition](#)

[Inverse](#)

[Answers to Practice Problems](#)

[Additional Resources](#)

Arithmetic, Order of Operations, Radicals

Perform the indicated operation(s). Simplify expressions as much as possible. Write fractions in reduced form. Do not use mixed fractions. Do not use decimals. Do not use a calculator.

1. $\frac{1}{2} + \frac{5}{4} - \frac{2}{3}$

2. $2 - \frac{4}{3} \div \frac{5}{6}$

3. $12 - 2\sqrt{16+9}$

4. $\frac{1}{\sqrt{3}} + \frac{\sqrt{2}}{2}$

Factoring polynomials

Factor completely.

5. $20 + 5m + 12n + 3mn$

6. $y^2 + 7y - 30$

7. $20x^2 + 47x + 24$

8. $25x^2 - 90x + 81$

9. $24x^2 + 42x + 15$

10. $p^4 - 10p^2 + 16$

11. $x^4 - 81$

12. $x^5 + 3x^4 - x - 3$

13. $2a^3 + a^2 - 14a - 7$

14. $p^2 + 15p + 56$

15. $27z^2 + 42z - 5$

16. $14c^2 - 17cd - 6d^2$

17. $6a^3 + 12a^2 - 90a$

18. $100a^2 - 9b^2$

19. $16x^3 + 32x^2 - 9x - 18$

20. $x^9 - 1$

Simplifying expressions

Rational Expressions

$$\bullet \frac{x^2 - 25}{x^2 + x - 20} \div \frac{x^2 - 2x - 15}{x^2 + 7x + 12}$$

$$\frac{(x+5)(x-5)}{(x+5)(x-4)} \div \frac{(x-5)(x+3)}{(x+4)(x+3)} = \frac{\cancel{(x+5)} \cancel{(x-5)}}{\cancel{(x+5)}(x-4)} \cdot \frac{(x+4)\cancel{(x+3)}}{\cancel{(x-5)}\cancel{(x+3)}} = \frac{x+4}{x-4}$$

$$\bullet \frac{x-3}{x+2} - \frac{x+4}{x-2}$$

$$= \frac{(x-3)(x-2) - (x+4)(x+2)}{(x+2)(x-2)} = \frac{x^2 - 5x + 6 - x^2 - 6x - 8}{(x+2)(x-2)} = \frac{-11x - 2}{(x+2)(x-2)}$$

Complex Fractions (Mixed Quotients)

Recall that to divide rational expressions you must multiply by the reciprocal of the denominator. This only works if you are dividing a single rational expression by another.

There are two methods for simplifying complex fractions.

Method 1:

$$\frac{\frac{2}{x} - \frac{3}{y}}{\frac{4}{x^2} + \frac{6}{y^2}} = \frac{\frac{2y}{xy} - \frac{3x}{yx}}{\frac{4y^2}{x^2y^2} + \frac{6x^2}{x^2y^2}} = \frac{\frac{2y-3x}{xy}}{\frac{4y^2+6x^2}{x^2y^2}} = \frac{2y-3x}{xy} \cdot \frac{x^2y^2}{4y^2+6x^2} = \frac{xy(2y-3x)}{4y^2+6x^2}$$

Method 2:

$$\frac{\frac{2}{x} - \frac{3}{y}}{\frac{4}{x^2} + \frac{6}{y^2}} = \left(\frac{\frac{2}{x} - \frac{3}{y}}{\frac{4}{x^2} + \frac{6}{y^2}} \right) \cdot \frac{x^2y^2}{x^2y^2} = \frac{\frac{2x^2y^2}{x} - \frac{3x^2y^2}{y}}{\frac{4x^2y^2}{x^2} + \frac{6x^2y^2}{y^2}} = \frac{2xy^2 - 3x^2y}{4y^2 + 6x^2} = \frac{xy(2y-3x)}{4y^2 + 6x^2}$$

Examples. Simplify the expression. Write the expression as a single quotient in which only positive exponents and/or radicals appear.

$$\bullet \frac{\frac{2}{x} - \frac{3}{y}}{\frac{4y}{x} - \frac{9x}{y}}$$

$$\frac{\left(\frac{2}{x} - \frac{3}{y} \right)}{\left(\frac{4y}{x} - \frac{9x}{y} \right)} \cdot \frac{(xy)}{(xy)} = \frac{2y-3x}{4y^2-9x^2} = \frac{2y-3x}{(2y+3x)(2y-3x)} = \frac{1}{2y+3x}$$

- $\frac{x^{-2} - 25y^{-2}}{x^{-1} - 5y^{-1}}$

CAUTION:

$$\frac{1}{a+b} = (a+b)^{-1} \neq a^{-1} + b^{-1}$$

$$\frac{\left(\frac{1}{x^2} - \frac{25}{y^2}\right) \cdot x^2 y^2}{\left(\frac{1}{x} - \frac{5}{y}\right) \cdot x^2 y^2} = \frac{y^2 - 25x^2}{xy^2 - 5x^2 y} = \frac{(y+5x)(y-5x)}{xy(y-5x)} = \frac{y+5x}{xy}$$

Your Turn. Perform the indicated operation. Simplify if possible.

21. $\frac{c^2 + 2c}{c^2 - 4} \cdot \frac{c^2 - 4c + 4}{c^2 - c}$

22. $\frac{z^2 + 2z}{5+z} \div \frac{4-z^2}{3z-6}$

23. $\frac{15}{x^2 + 3x} + \frac{2}{x} + \frac{5}{x+3}$

24. $\frac{4}{x+1} + \frac{1}{x^2 - x + 1} - \frac{12}{x^3 + 1}$

25. $\frac{\frac{x}{1} - \frac{16y}{4}}{\frac{y}{x}}$

26. $\frac{\frac{x}{x-2} + 1}{\frac{3}{x^2 - 4} + 1}$

Solving equations

Quadratic equations

Factoring.

- $y(y-9) = -14$

$$y^2 - 9y + 14 = 0 \rightarrow (y-7)(y-2) = 0$$

$$y-7 = 0 \rightarrow y = 7$$

$$y-2 = 0 \rightarrow y = 2$$

$$\{2, 7\}$$

The square root property.

- $3x^2 - 54 = 0$

$$x^2 = 18 \rightarrow x = \pm\sqrt{18} = \pm 3\sqrt{2}$$

$$\{\pm 3\sqrt{2}\}$$

- $(2x+3)^2 = 36$

$$2x+3 = \pm\sqrt{36} \rightarrow x = \frac{-3 \pm 6}{2}$$

$$\left\{-\frac{9}{2}, \frac{3}{2}\right\}$$

Completing the square.

- $x^2 + 6x + 2 = 0$

$$x^2 + 6x + \left(\frac{6}{2}\right)^2 = -2 + \left(\frac{6}{2}\right)^2 \rightarrow x^2 + 6x + 9 = -2 + 9 \rightarrow (x+3)^2 = 7 \rightarrow x+3 = \pm\sqrt{7} \rightarrow x = -3 \pm \sqrt{7}$$

$$\{-3 \pm \sqrt{7}\}$$

The quadratic formula.

- $-2x(x+2) = -3$

$$-2x^2 - 4x + 3 = 0 \rightarrow 2x^2 + 4x - 3 = 0 \rightarrow x = \frac{-4 \pm \sqrt{(4)^2 - 4(2)(-3)}}{2(2)} = \frac{-4 \pm \sqrt{40}}{4} = \frac{-4 \pm 2\sqrt{10}}{4} = \frac{-2 \pm \sqrt{10}}{2}$$

$$\left\{\frac{-2 \pm \sqrt{10}}{2}\right\}$$

Rational

- $3x = 1 - \frac{1}{x}$

$$3x^2 = x - 1 \rightarrow 3x^2 - x + 1 = 0 \rightarrow x = \frac{1 \pm \sqrt{1-12}}{6}$$

$$\left\{ \frac{1 \pm i\sqrt{11}}{6} \right\}$$

- $\frac{1}{x-5} = \frac{1}{x^2-4x-5} + \frac{6}{x+1}$

$$\left(\frac{1}{x-5} \right) (x-5)(x+1) = \left[\frac{1}{(x-5)(x+1)} + \frac{6}{x+1} \right] (x-5)(x+1) \quad x \neq \{-1, 5\}$$

$$x+1 = 1 + 6(x-5) \rightarrow x+1 = 1 + 6x - 30 \rightarrow -5x = -30 \rightarrow x = 6$$

$$\{6\}$$

Factoring

- $p^3 - 25p = 0$

$$p(p+5)(p-5) = 0 \rightarrow p = \{0, \pm 5\}$$

- $x^4 + 3x^3 = 4x^2 + 12x$

$$x^4 + 3x^3 - 4x^2 - 12x = 0 \rightarrow x(x^3 + 3x^2 - 4x - 12) = 0$$

$$x(x^2(x+3) - 4(x+3)) = 0 \rightarrow x(x+3)(x^2 - 4) = 0 \rightarrow x = \{0, -3, \pm 2\}$$

- $x^3 + 8 = 0$

$$x^3 + 2^3 = 0 \rightarrow (x+2)(x^2 - 2x + 4) = 0$$

$$x+2 = 0 \rightarrow x = -2$$

$$x^2 - 2x + 4 \rightarrow x = \frac{2 \pm \sqrt{4-16}}{2} = \frac{2 \pm \sqrt{-12}}{2} = \frac{2 \pm 2i\sqrt{3}}{2} = 1 \pm i\sqrt{3}$$

$$\{-2, 1 \pm i\sqrt{3}\}$$

Quadratic in form

- $2x^4 + 4 = 7x^2$

$$2x^4 - 7x^2 + 4 = 0 \rightarrow (2x^2 + 1)(x^2 - 4) = 0$$

$$2x^2 + 1 \rightarrow x = \pm \sqrt{-\frac{1}{2}} = \pm \frac{i}{\sqrt{2}} = \pm \frac{i\sqrt{2}}{2}$$

$$x^2 - 4 = 0 \rightarrow x = \pm 2$$

$$\left\{ \pm 2, \pm \frac{i\sqrt{2}}{2} \right\}$$

Square root

- $\sqrt{8-t} - \sqrt{26+t} = -2$

$$(\sqrt{8-t})^2 = (-2 + \sqrt{26+t})^2$$

$$8-t = 4 - 4\sqrt{26+t} + 26+t$$

$$-2t - 22 = -4\sqrt{26+t}$$

$$t + 11 = 2\sqrt{26+t}$$

$$t^2 + 22t + 121 = 4(26+t) \rightarrow t^2 + 18t + 17 = 0 \rightarrow (t+17)(t+1) = 0$$

$$\sqrt{8-(-17)} - \sqrt{26+(-17)} = 5 - 3 = 2 \neq -2$$

$$\sqrt{8-(-1)} - \sqrt{26+(-1)} = 3 - 5 = -2$$

$$\{-1\}$$

Absolute Value

Recall the definition of absolute value: $|a| = \begin{cases} a, & a \geq 0 \\ -a, & a < 0 \end{cases}$

- $|2x-5| - 3 = 12$

$$|2x-5| = 15$$

$$2x-5 = \pm 15 \rightarrow x = \frac{5 \pm 15}{2} \rightarrow x = \{-5, 10\}$$

Your Turn. Find all solutions to each equation.

Provide exact answers (no decimals). Simplify all answers as much as possible.

27. $\frac{-12}{x} = x + 8$

28. $\frac{3}{2x} - \frac{1}{4x+2} = 1$

29. $(4x-7)^2 = 81$

30. $2x^2 - 5x + 3 = 0$

31. $x^4 - 29x^2 + 100 = 0$

32. $(2x+5)^2 - 6 = 4(2x+5)$

33. $4m^{4/3} - 13m^{2/3} + 9 = 0$

34. $3x = \sqrt{16-10x}$

35. $(3x-5)^2 + 12 = 0$

36. $\frac{12}{g^2-2g} + 3 = \frac{6}{g-2}$

37. $(x+9)(x-1) = (x+1)^2$

38. $\sqrt{x-6} + 2 = 5$

Systems of linear equations

Recall that the solution to a system of linear equations is an ordered pair (x, y) , which corresponds to the point of intersection of the graphs of the two lines.

Example:

$$\begin{aligned} 4x + y &= 5 \\ 2x - 3y &= 13 \end{aligned}$$

We can see from the graph that the two lines appear to intersect at the point $(2, -3)$. It is not always easy to determine the point of intersection simply by inspecting a graph. We find this solution by solving the system algebraically using one of two methods: substitution or elimination.

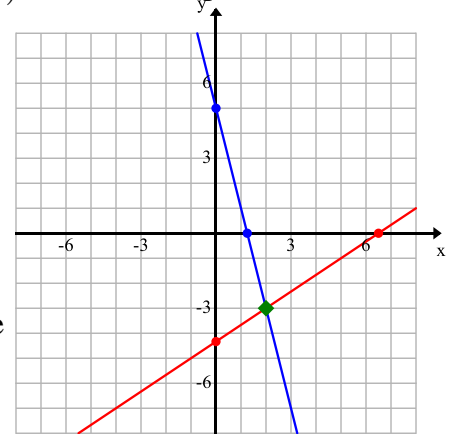

Method 1: Substitution. Select one equation and one variable in that equation. Solve for the variable. Then, substitute your expression into the *other* equation.

The variable y is easy to solve for in the first equation: $4x + y = 5 \rightarrow y = 5 - 4x$

Substitute this expression into the second equation: $2x - 3y = 13 \rightarrow 2x - 3(5 - 4x) = 13$

Solve this equation and we get $x = 2$.

We still need our y -coordinate. As we already have an equation that is solved for y , we plug in $x = 2$ and evaluate: $y = 5 - 4x \rightarrow y = 5 - 4(2) = -3$

Therefore, the solution to our system is the point $(2, -3)$.

Method 2: Elimination (aka Addition). The goal here is to manipulate one or both equations such that the coefficients on *one* of the variables is the same number, but opposite sign, in both equations. Then, we add the equations, term by term. If done correctly, one of the variables should be eliminated.

For our example, we can see that we can make the coefficients of the variable x both equal to 4 by multiplying the *second* equation by a factor of 2. However, remember that we want them to be opposite signs, so we multiply by -2 :

$$(-2)(2x - 3y) = (13)(-2)$$

Now we have the following system and we add *vertically*, term by term:

$$\begin{array}{r} 4x + y = 5 \\ -4x + 6y = -26 \\ \hline 7y = -21 \rightarrow y = -3 \end{array}$$

Once again, the solution to our system is found to be the point $(2, -3)$.

Your turn. Solve the systems algebraically using both methods. Then, graph the lines and inspect the graphs to see if your answers seem *reasonable*.

39.
$$\begin{cases} 2x + y = 5 \\ -x + 3y = 6 \end{cases}$$

40.
$$\begin{cases} 2x + 3y = 19 \\ 3x - 7y = -6 \end{cases}$$

Systems of Non-Linear Equations

Examples. Find all points of intersection and graph the system of equations.

$$\begin{cases} x^2 + y^2 = 25 \\ 4x - 3y = 0 \end{cases}$$

$$y = \frac{4}{3}x$$

$$x^2 + \left(\frac{4}{3}x\right)^2 = 25$$

$$\frac{25}{9}x^2 = 25$$

$$x = \pm 3$$

$$y = \frac{4}{3}(3) = 4$$

$$y = \frac{4}{3}(-3) = -4$$

POI: $(-3, -4), (3, 4)$

Intercepts: $(\pm 5, 0), (0, 0), (0, \pm 5)$

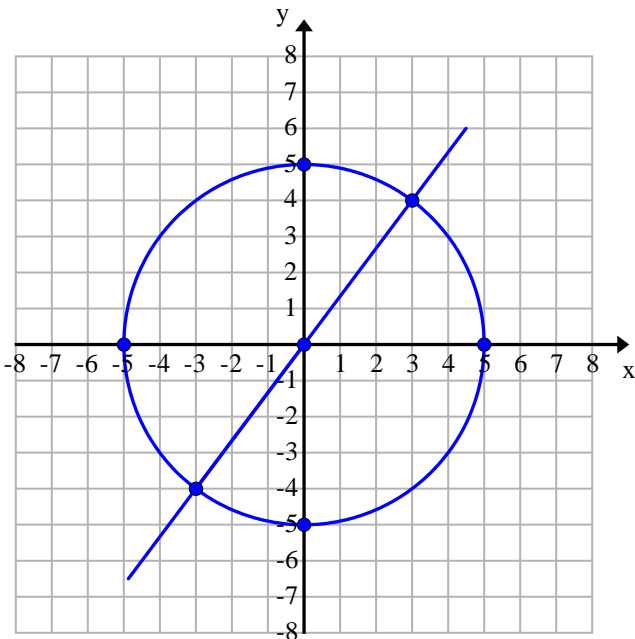

$$\begin{cases} y = -2x^2 + 9 \\ x = \sqrt{y} \end{cases}$$

$$x = \sqrt{y}$$

$$y = -2(\sqrt{y})^2 + 9$$

$$y = -2y + 9$$

$$y = 3$$

$$x = \sqrt{3}$$

POI: $(\sqrt{3}, 3)$

Intercepts: $\left(\pm\sqrt{\frac{9}{2}}, 0\right), (0, 0), (0, 9)$

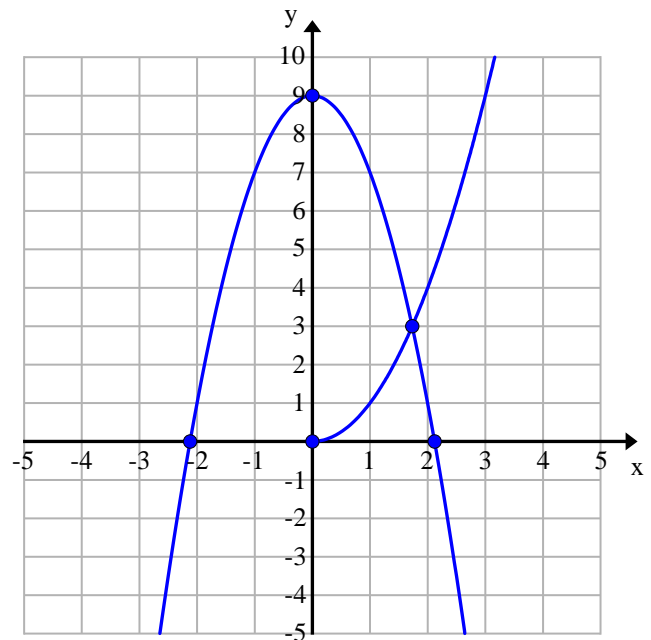

Your Turn. Solve the systems algebraically. Then, graph the equations on the same coordinate system and label all points of intersection.

41.
$$\begin{cases} y = x^2 - 12x + 36 \\ y = -x + 8 \end{cases}$$

$$42. \begin{cases} x^2 + y^2 = 9 \\ y = x^2 - 3 \end{cases}$$

$$43. \begin{cases} y^2 - 12 = -3x \\ x - y = -2 \end{cases}$$

Geometry

Pythagorean Theorem

Find the length of the missing side in each **right** triangle.

44. Legs 24 and 48

45. Leg $\sqrt{5}$ and hypotenuse 3

Areas

Find the exact area of the shaded region in each figure.

46.

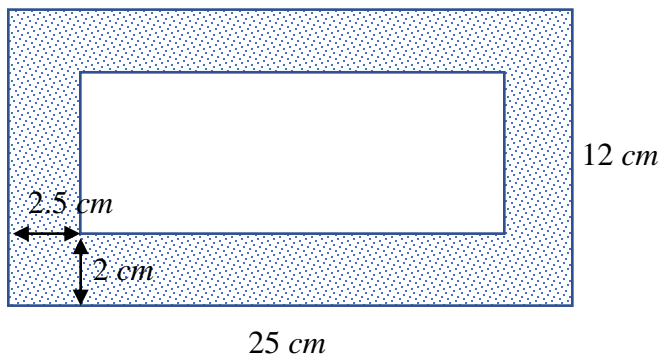

47.

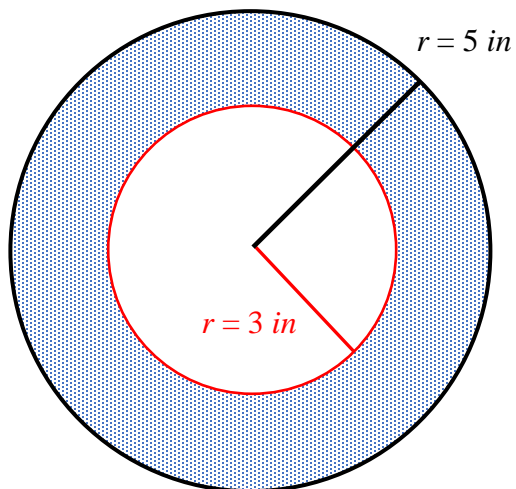

48.

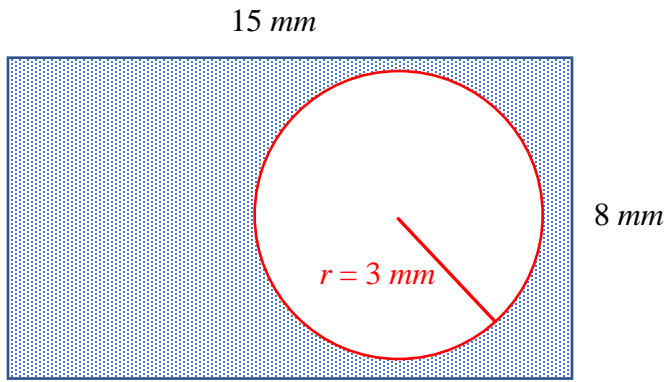

49.

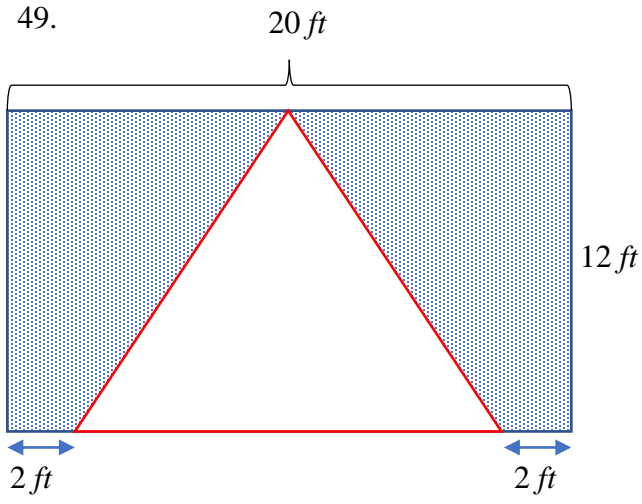

Functions

Transformations

Sketch the graph of each of the following. Find domain, range, and intercepts.

50. $f(x) = (x-4)^2 - 9$

51. $f(x) = (x+1)^3 - 8$

52. $x = (y-2)^2 - 9$

53. $f(x) = -\sqrt{x+7} - 2$

54. $f(x) = \sqrt{4x}$

55. $f(x) = -|x-2| + 5$

Domain

State the domain of each function.

56. $f(x) = \frac{x^2 - 9}{4x^2 + 17x + 15}$

57. $g(x) = \sqrt{16 - x^2}$

58. $h(x) = \frac{\sqrt{3x+5}}{x-6}$

Composition

Def: Given two functions f and g , the **composite function** $(f \circ g)(x)$ is defined by $f(g(x))$.

$(f \circ g)(x)$ is read as, “ f composed with g at x .”

$f(g(x))$ is read as, “ f of g of x .”

Composition uses two (or more) functions to create a new one.

The **domain** of $(f \circ g)(x)$ is all x such that x is in the domain of g **AND** $g(x)$ is in the domain of f .

Example.

$$f(x) = \sqrt{5+x}; g(x) = x+1$$

$$(f \circ g)(x) = f(g(x)) = \sqrt{5+(x+1)} = \sqrt{x+6}$$

Domain:

$$x \in \text{domain } g \rightarrow x \in \mathbb{R}$$

$$g(x) \in \text{domain } f \rightarrow 5+g(x) \geq 0 \rightarrow 5+(x+1) \geq 0 \rightarrow x+6 \geq 0 \rightarrow x \geq -6$$

$$[-6, \infty)$$

Find $(f \circ g)(x)$ and state the domain of the resulting function.

59. $f(x) = \frac{x}{x+6}; g(x) = \frac{30}{x+4}$

60. $f(x) = \sqrt{x-5}; g(x) = x^2 - 4$

Inverse

Def.: A function is said to be **one-to-one** if $x_1 \neq x_2 \Rightarrow f(x_1) \neq f(x_2)$.

Simply put, different inputs (x -values) give you different outputs (y -values).

If $y = f(x)$ is a one-to-one function, then we define its inverse as $x = f^{-1}(y)$.

a) The *domain* of $y = f(x)$ is the *range* of $x = f^{-1}(y)$.

b) The *range* of $y = f(x)$ is the *domain* of $x = f^{-1}(y)$.

If we compose a function and its inverse, we have the following:

a) $f(f^{-1}(y)) = y$ for all y in the domain of the inverse such that $f^{-1}(y)$ is in the domain of f

b) $f^{-1}(f(x)) = x$ for all x in the domain of the function such that $f(x)$ is in the domain of f^{-1}

Example. Show the given functions are inverses. State the domain and range of each function.

$$f(x) = \frac{3x}{2x+5} \text{ and } g(x) = \frac{5x}{3-2x}$$

$$(f \circ g)(x) = f\left(\frac{5x}{3-2x}\right) = \frac{3\left(\frac{5x}{3-2x}\right)}{2\left(\frac{5x}{3-2x}\right)+5} = \frac{15x}{10x+5(3-2x)} = \frac{15x}{15} = x$$

$$(g \circ f)(x) = g\left(\frac{3x}{2x+5}\right) = \frac{5\left(\frac{3x}{2x+5}\right)}{3-2\left(\frac{3x}{2x+5}\right)} = \frac{15x}{3(2x+5)-6x} = \frac{15x}{15} = x$$

$$Df : \mathbb{R} \setminus \left\{-\frac{5}{2}\right\} = Rg$$

$$Dg : \mathbb{R} \setminus \left\{\frac{3}{2}\right\} = Rf$$

Find the inverse function of f . State the domain of f and f^{-1} . For #62, sketch the graph of the function and its inverse on the same coordinate plane.

61. $f(x) = 1 + (x-2)^3$

62. $f(x) = \sqrt{x+4} - 5$

Answers to Your Turn Problems

$$1. \quad \frac{1(6)+5(3)-2(4)}{12} = \frac{13}{12}$$

$$2. \quad 2 - \frac{4}{3} \cdot \frac{6}{5} = 2 - \frac{8}{5} = \frac{2(5)-8}{5} = \frac{2}{5}$$

$$3. \quad 12 - 2\sqrt{25} = 12 - 2(5) = 12 - 10 = 2$$

$$4. \quad \frac{1}{\sqrt{3}} + \frac{\sqrt{2}}{2} = \frac{2+\sqrt{6}}{2\sqrt{3}} \text{ or } \frac{\sqrt{3}}{3} + \frac{\sqrt{2}}{2} = \frac{2\sqrt{3}+3\sqrt{2}}{6}$$

$$5. \quad (4+m)(5+3n)$$

$$6. \quad (y+10)(y-3)$$

$$7. \quad (4x+3)(5x+8)$$

$$8. \quad (5x-9)^2$$

$$9. \quad (6x+3)(4x+5)$$

$$10. \quad (p^2-2)(p^2-8)$$

$$11. \quad (x^2+9)(x+3)(x-3)$$

$$12. \quad (x+3)(x^2+1)(x+1)(x-1)$$

$$13. \quad (2a+1)(a^2-7)$$

$$14. \quad (p+8)(p+7)$$

$$15. \quad (9z-1)(3z+5)$$

$$16. \quad (7c+2d)(2c-3d)$$

$$17. \quad 6a(a+5)(a-3)$$

$$18. \quad (10a+3b)(10a-3b)$$

$$19. (x+2)(4x+3)(4x-3)$$

$$20. (x-1)(x^2+x+1)(x^6+x^3+1)$$

$$21. \frac{c(c+2)}{(c+2)(c-2)} \cdot \frac{(c-2)^2}{c(c-1)} = \frac{c-2}{c-1}$$

$$22. \frac{z(z+2)}{5+z} \cdot \frac{3(z-2)}{(2-z)(2+z)} = \frac{3z(z-2)}{(5+z)(2-z)} = -\frac{3z}{5+z}$$

$$23. \frac{15+2(x+3)+5x}{x(x+3)} = \frac{7x+21}{x(x+3)} = \frac{7(x+3)}{x(x+3)} = \frac{7}{x}$$

$$24. \frac{4(x^2-x+1)+1(x+1)-12}{(x+1)(x^2-x+1)} = \frac{4x^2-3x-7}{(x+1)(x^2-x+1)} = \frac{(4x-7)(x+1)}{(x+1)(x^2-x+1)} = \frac{4x-7}{x^2-x+1}$$

$$25. \frac{\left(\frac{x}{y} - \frac{16y}{x}\right)}{\left(\frac{1}{y} - \frac{4}{x}\right)} \cdot \frac{xy}{xy} = \frac{x^2-16y^2}{x-4y} = \frac{(x+4y)(x-4y)}{x-4y} = x+4y$$

$$26. \frac{\frac{x}{x-2}+1}{\frac{3}{x^2-4}+1} = \frac{\frac{x+x-2}{x-2}}{\frac{3+x^2-4}{x^2-4}} = \frac{2x-2}{x-2} \cdot \frac{x^2-4}{x^2-1} = \frac{2(x-1)}{x-2} \cdot \frac{(x+2)(x-2)}{(x+1)(x-1)} = \frac{2(x+2)}{x+1}$$

$$27. -12 = x^2 + 8x \text{ and } x \neq 0 \rightarrow x^2 + 8x + 12 = 0 \rightarrow (x+6)(x+2) = 0 \rightarrow \{-6, -2\}$$

$$28. 3(2x+1) - x = 2x(2x+1) \text{ and } x \neq 0, -\frac{1}{2}$$

$$\rightarrow 6x+3-x = 4x^2+2x \rightarrow 4x^2-3x-3=0 \rightarrow x = \frac{3 \pm \sqrt{9+48}}{8} = \left\{ \frac{3 \pm \sqrt{57}}{8} \right\}$$

$$29. 4x-7 = \pm 9 \rightarrow x = \frac{7 \pm 9}{4} \rightarrow x = \left\{ -\frac{1}{2}, 4 \right\}$$

$$30. (2x-3)(x-1) = 0 \rightarrow x = \left\{ 1, \frac{3}{2} \right\}$$

$$31. (x^2-25)(x^2-4) = 0 \rightarrow x^2 = 25 \text{ or } x^2 = 4 \rightarrow x = \{\pm 5, \pm 2\}$$

$$(2x+5)^2 - 4(2x+5) - 6 = 0 \rightarrow u = 2x+5$$

$$32. \quad u^2 - 4u - 6 = 0 \rightarrow u^2 - 4u + 4 = 6 + 4 \rightarrow (u-2)^2 = 10 \rightarrow u = 2 \pm \sqrt{10}$$

$$2x+5 = 2 \pm \sqrt{10} \rightarrow x = \left\{ \frac{-3 \pm \sqrt{10}}{2} \right\}$$

$$(4m^{2/3} - 9)(m^{2/3} - 1) = 0 \rightarrow m^{2/3} = \frac{9}{4} \text{ or } m^{2/3} = 1$$

$$33. \quad \rightarrow m^{1/3} = \pm \frac{3}{2} \text{ or } m^{1/3} = \pm 1 \rightarrow m = \pm \frac{27}{8} \text{ or } m = \pm 1 \rightarrow m = \left\{ \pm \frac{27}{8}, \pm 1 \right\}$$

$$9x^2 = 16 - 10x \rightarrow 9x^2 + 10x - 16 = 0 \rightarrow (9x-8)(x+2) = 0 \rightarrow x = \frac{8}{9} \text{ or } x = -2$$

$$34. \quad 3\left(\frac{8}{9}\right) \stackrel{?}{=} \sqrt{16 - 10\left(\frac{8}{9}\right)} \rightarrow \frac{8}{3} = \sqrt{\frac{64}{9}} \text{ yes}$$

$$3(-2) \stackrel{?}{=} \sqrt{16 - 10(-2)} \rightarrow -6 = \sqrt{36} \text{ no} \rightarrow x = \left\{ \frac{8}{9} \right\}$$

$$35. \quad 3x - 5 = \pm \sqrt{12} \rightarrow x = \left\{ \frac{5 \pm 2\sqrt{3}}{3} \right\}$$

$$36. \quad 12 + 3(g^2 - 2g) = 6g \text{ and } g \neq 0, 2 \rightarrow 3g^2 - 12g + 12 = 0 \rightarrow 3(g-2)^2 = 0 \rightarrow g = 2! \rightarrow \emptyset$$

$$37. \quad x^2 + 8x - 9 = x^2 + 2x + 1 \rightarrow 6x = 10 \rightarrow x = \left\{ \frac{5}{3} \right\}$$

$$x - 6 = 9 \rightarrow x = 15$$

$$38. \quad \sqrt{15-6} + 2 = \sqrt{9} + 2 = 3 + 2 = 5 \rightarrow x = \{15\}$$

$$39. \quad \left(\frac{9}{7}, \frac{17}{7} \right)$$

$$40. \quad (5, 3)$$

41.

$$x^2 - 12x + 36 = -x + 8$$

$$x^2 - 11x + 28 = 0 \rightarrow (x-4)(x-7) = 0 \rightarrow x = 4, x = 7$$

$$y = -x + 8 \rightarrow (4, 4), (7, 1)$$

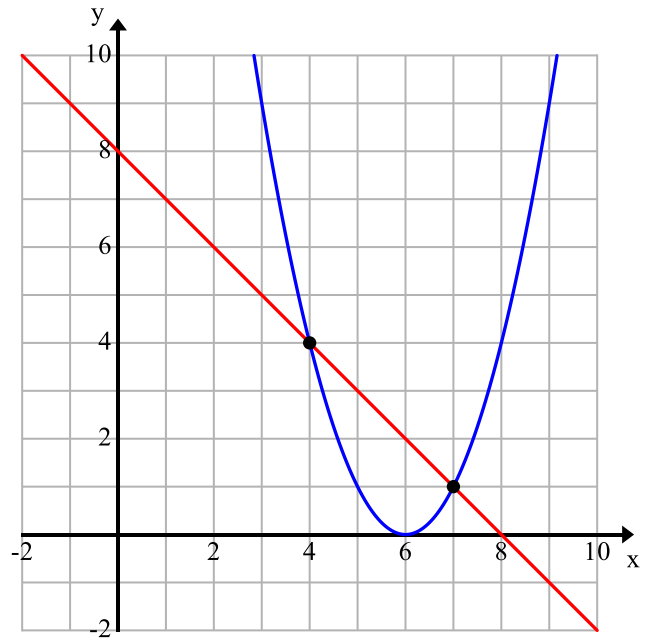

42.

$$x^2 = y + 3$$

$$(y+3) + y^2 = 9 \rightarrow y^2 + y - 6 = 0$$

$$\rightarrow (y+3)(y-2) = 0 \rightarrow y = -3, y = 2$$

$$x = \pm\sqrt{y+3} \rightarrow (0, -3), (\pm\sqrt{5}, 2)$$

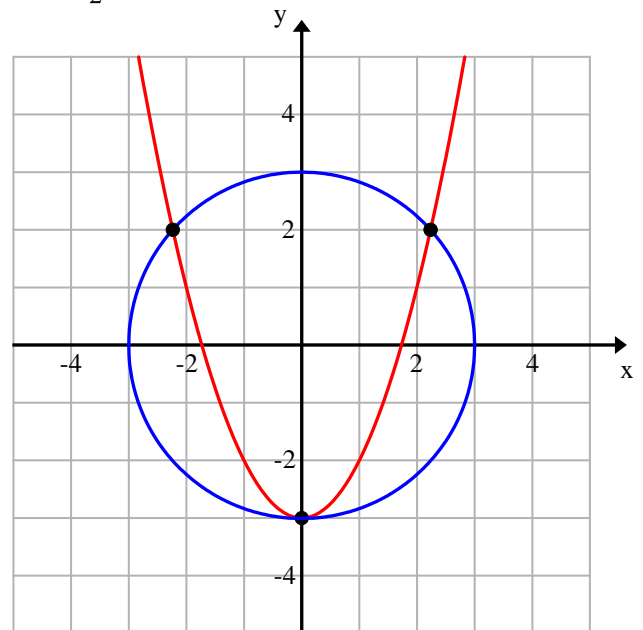

43.

$$x = y - 2$$

$$y^2 - 12 = -3(y - 2) \rightarrow y^2 + 3y - 18 = 0$$

$$\rightarrow (y+6)(y-3) = 0 \rightarrow y = -6, y = 3$$

$$x = y - 2 \rightarrow (-8, -6), (1, 3)$$

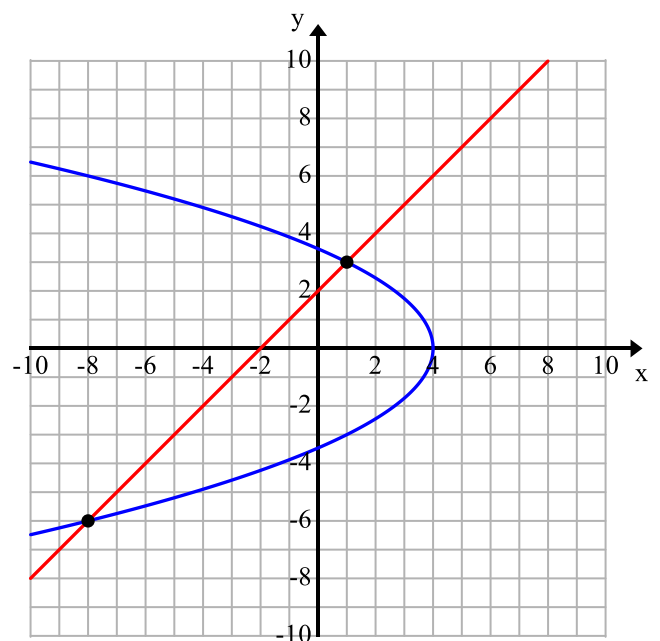

44. $\sqrt{24^2 + 48^2} = \sqrt{2880} = 24\sqrt{2}$

45. $\sqrt{3^2 - \sqrt{5}^2} = \sqrt{4} = 2$

46. $A = (25\text{ cm})(12\text{ cm}) - (20\text{ cm})(8\text{ cm}) = 140\text{ cm}^2$

47. $A = \pi(5\text{ in})^2 - \pi(3\text{ in})^2 = 16\pi\text{ in}^2$

48. $A = (15\text{ mm})(8\text{ mm}) - \pi(3\text{ mm})^2 = 120 - 9\pi\text{ mm}^2$

49. $A = (20\text{ ft})(12\text{ ft}) - \frac{1}{2}(16\text{ ft})(12\text{ ft}) = 144\text{ ft}^2$

50.

x-int: $(x-4)^2 - 9 = 0 \rightarrow (x-4)^2 = 9$
 $\rightarrow x-4 = \pm 3 \rightarrow x = 4 \pm 3 \rightarrow (7, 0); (1, 0)$

y-int: $f(0) = (0-4)^2 - 9 = 16 - 9 = 7 \rightarrow (0, 7)$

Vertex: $V(4, -9)$

Additional Points (there are many options): $(2, -5), (6, -5)$

Domain: \square

Range: $[-9, \infty)$

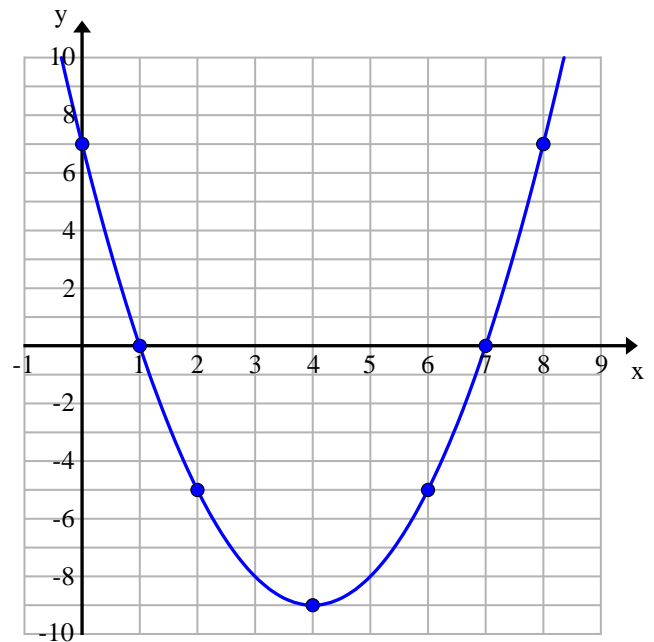

51.

x-int: $(x+1)^3 - 8 = 0 \rightarrow x+1 = \sqrt[3]{8} \rightarrow x = -1 + 2 \rightarrow (1, 0)$

y-int: $f(0) = (0+1)^3 - 8 = -7 \rightarrow (0, -7)$

Ref. Point: $(-1, -8)$

Additional Point : $(-2, -9)$

Domain: \square

Range: \square

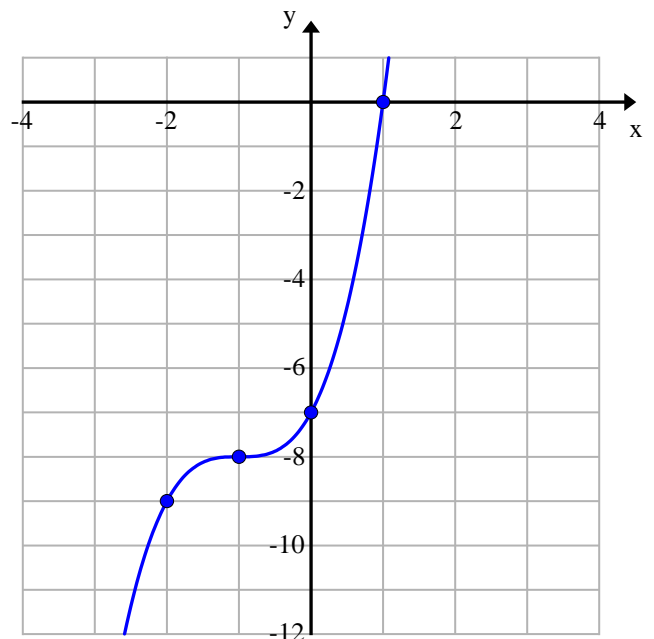

52.

x-int: $x = (0-2)^2 - 9 \rightarrow x = 4 - 9 = -5 \rightarrow (-5, 0)$

y-int: $0 = (y-2)^2 - 9 \rightarrow y = 2 \pm 3 \rightarrow (0, 5); (0, -1)$

Vertex: $V(-9, 2)$

Additional Points: $(-5, 4)$

Domain: $[-9, \infty)$

Range: \square

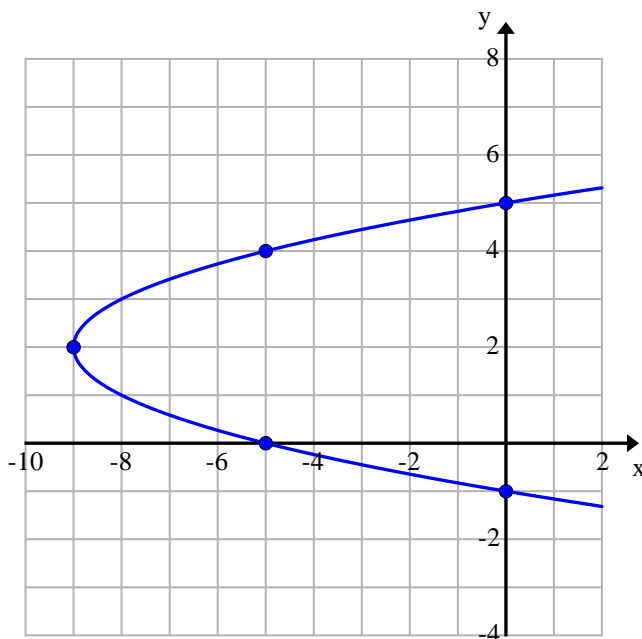

53.

Domain: $x+7 \geq 0 \rightarrow [-7, \infty)$

x-int: $-\sqrt{x+7} - 2 = 0 \rightarrow \sqrt{x+7} = -2 \rightarrow \text{NONE}$

y-int: $f(0) = -\sqrt{0+7} - 2 \rightarrow (0, -\sqrt{7} - 2)$

Starting point: $(-7, -2)$

Additional Points: $(2, -5), (9, -6)$

Range: $(-\infty, -2]$

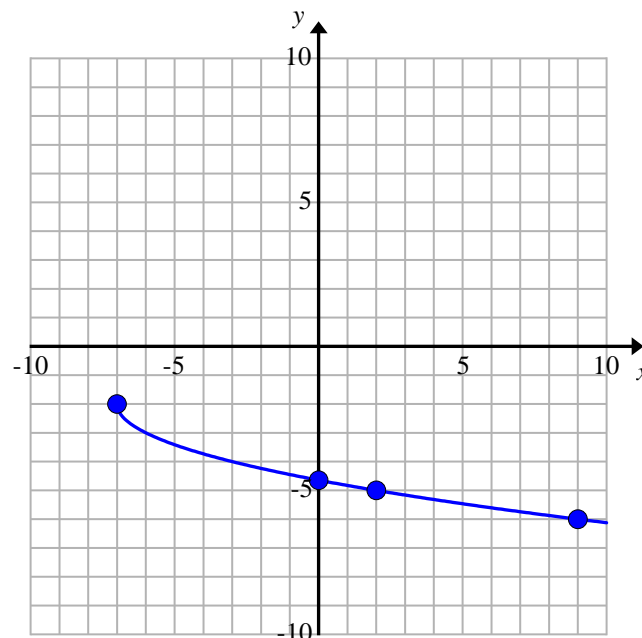

54.

Domain: $4x \geq 0 \rightarrow [0, \infty)$

x-int: $(0, 0)$

y-int: $(0, 0)$

Starting point: $(0, 0)$

Additional Points: $(\frac{1}{4}, 1), (1, 2), (\frac{9}{4}, 3), (4, 4)$

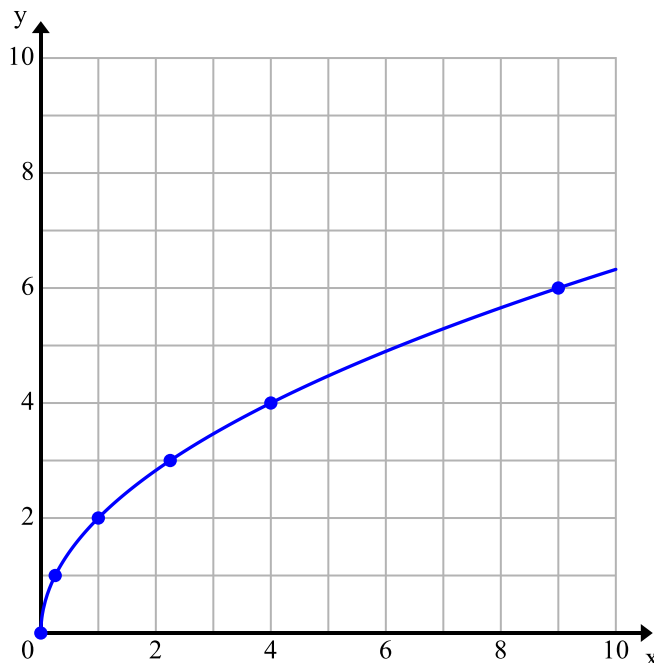

Range: $[0, \infty)$

55.

x-int: $-|x-2|+5=0 \rightarrow |x-2|=5 \rightarrow x-2=\pm 5 \rightarrow (7, 0), (-3, 0)$

y-int: $f(0)=-|x-2|+5=-2+5 \rightarrow (0, 3)$

Vertex: $(2, 5)$

Additional Points: $(4, 3)$

Domain: \mathbb{R}

Range: $(-\infty, 5]$

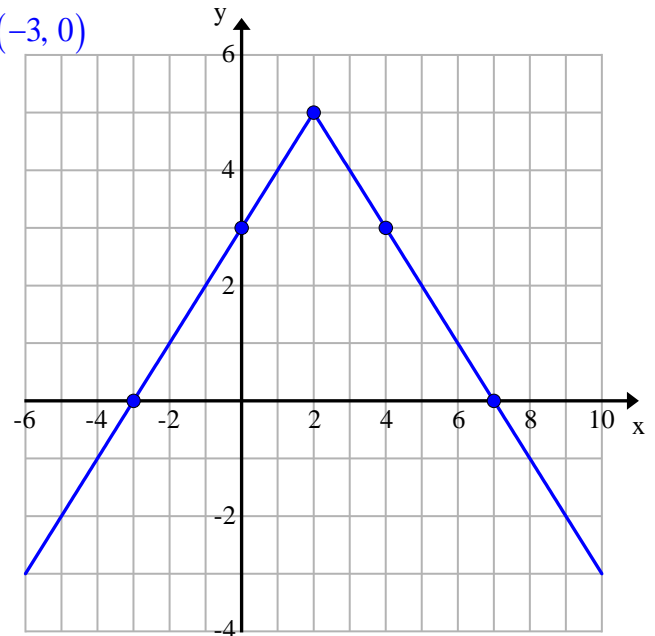

56. $4x^2+17x+15 \neq 0 \rightarrow (4x+5)(x+3) \neq 0 \rightarrow \mathbb{R} \setminus \left\{-3, -\frac{5}{4}\right\}$

57. $16-x^2 \geq 0 \rightarrow (4-x)(4+x) \geq 0 \rightarrow [-4, 4]$

58. $3x+5 \geq 0$ and $x-6 \neq 0 \rightarrow x \geq -\frac{5}{3}$ and $x \neq 6 \rightarrow \left[-\frac{5}{3}, 6\right) \cup (6, \infty)$

59.

$x \in \text{domain } g \rightarrow x \neq -4$

$g(x) \in \text{domain } f \rightarrow g(x) \neq -6 \rightarrow \frac{30}{x+4} \neq -6 \rightarrow 30 \neq -6x-24 \rightarrow x \neq -9$

$\mathbb{R} \setminus \{-9, -4\}$

60.

$x \in \text{domain } g \rightarrow x \in \mathbb{R}$

$g(x) \in \text{domain } f \rightarrow g(x)-5 \geq 0 \rightarrow x^2-4-5 \geq 0 \rightarrow x^2-9 \geq 0$

$(-\infty -3] \cup [3, \infty)$

61. $f(x) = 1 + (x - 2)^3$

$$x = 1 + (y - 2)^3 \rightarrow (y - 2)^3 = x - 1 \rightarrow f^{-1}(x) = \sqrt[3]{x - 1} + 2$$

$$Df : \square = Rf^{-1}$$

$$Rf : \square = Df^{-1}$$

62. $f(x) = \sqrt{x + 4} - 5$

$$Df : [-4, \infty) = Rf^{-1}$$

$$Rf : [-5, \infty) = Df^{-1}$$

$$x = \sqrt{y + 4} - 5 \rightarrow (x + 5)^2 = y + 4 \rightarrow f^{-1}(x) = (x + 5)^2 - 4, x \geq -5$$

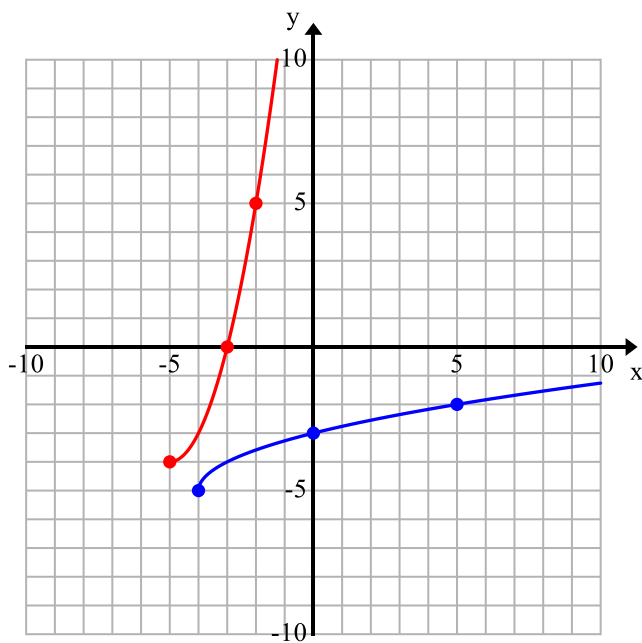

Additional Resource

<https://www.khanacademy.org/math/algebra-home>

[YouTube - Patrick JMT](#)